

# **ELEKTRA** **FreezeTec™**

**Heating Cables  
with integrated thermostat**



## **A** **Application**

ELEKTRA FreezeTec™ is intended for protection of pipes and valves susceptible to damage caused by low temperatures. The system may be used only when the following conditions are met:

- external diameter of pipe to be insulated should not exceed DN 50 mm;
- pipe insulation thickness should be between min. 10 mm and max. 20 mm;
- temperature of the protected pipe should not exceed +65°C;
- min. ambient temperature - 25°C.

# **C** **Characteristics and advantages**

ELEKTRA FreezeTec™ consists of a heating cable with a built-in thermostat, and operates automatically, eliminating the need for a separate control system usually used with conventional heating cables. The assembly of the system is quick, simple and does not need to be controlled.

## **Technical specifications:**

- thermostat turn-on temperature: +3 °C;
- turn-off temperature: + 10°C;
- power output: 12 W/m;
- power supply: 230V, 50/60 Hz.

# T Types of Cables

ELEKTRA FreezeTec™ cables are available as ready-made sets with integrated thermostat and three-conductor supply cold tail 1.5 m long.

Table I

TYPE	LENGTH OF HEATING CABLE	HEATING POWER	HEATING CONDUCTOR RESISTANCE
-	m	W	W
FreezeTec 12/2	2	24	2200
FreezeTec 12/3	3	36	1500
FreezeTec 12/5	5	60	900
FreezeTec 12/7	7	84	700
FreezeTec 12/10	10	120	448
FreezeTec 12/15	15	180	286
FreezeTec 12/21	21	252	204
FreezeTec 12/30	30	360	158
FreezeTec 12/42	42	504	104

**ATTENTION:** Values shown in the table may vary by up to 5%.

# Installation (Preparation)

Before the cable set is in place, the length of pipe to be heated should be measured in order to select the length of heating cable (Table 1) using a coefficient (Table 2) which will depend on the following:

- pipe diameter
- insulation thickness
- minimum ambient temperature

Table 2

INTERNAL DIAMETER OF PIPE DN [mm]	INCHES	INSULATION THICKNESS					
		10mm			20mm		
		AMBIENT TEMPERATURE					
		-10 °C	-15 °C	-25 °C	-10 °C	-15 °C	-25 °C
COEFFICIENT							
8	1/4	1	1	1	1	1	1
15	1/2	1	1	1	1	1	1
20	3/4	1	1	1,1	1	1	1
25	1	1	1	1,3	1	1	1
32	1 1/4	1	1,1	1,5	1	1	1
40	1 1/2	1,1	1,2	1,8	1	1	1,1
50	2	1,2	1,3	2,1	1	1	1,3

**Heating cable length = pipe length x coefficient**

(Table 2)

## STAGE I

The installation should be started by placing the thermostat (cable tail) on the pipe as shown in drawing 1. The thermostat should be located on the end of the pipe that is most at risk of lower ambient temperature.

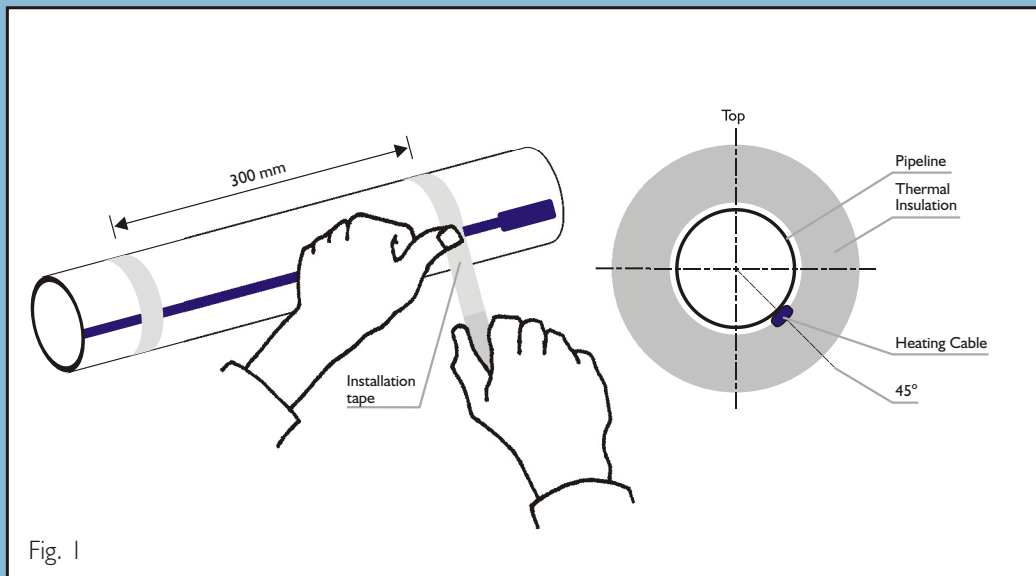

Fig. 1

## STAGE 2

The ELEKTRA FreezeTec™ heating set is laid along the pipe as shown on the Drawing (Fig. 2a) or helically wound around the pipe (Fig. 2b).

Method used to lay the cable (along or helically around the pipe) depends on the selected length of heating cable. Cables are attached by means of a tape.

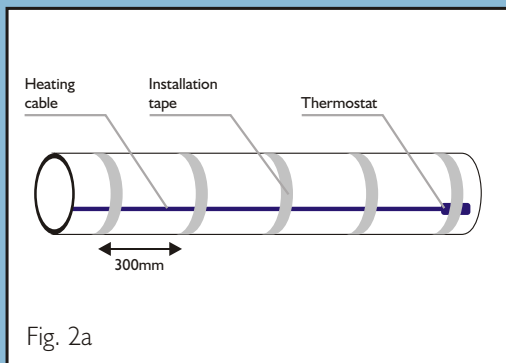

Fig. 2a

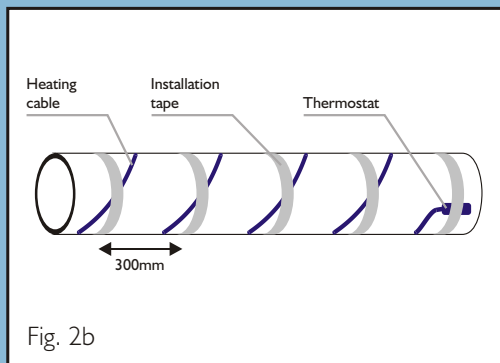

Fig. 2b



Installation tape  
(available with the heating set)

When the coefficient specified in table 2 has the value 1, the heating cable should be laid along the pipe (Fig. 2a). If the coefficient exceeds 1, the heating cable shall be wound around the pipe barrel (Fig. 2b).

### Example 1

- 14 m long 20 mm diameter pipe;
- insulation thickness: 10 mm;
- min. ambient temperature : -15°C;
- the pipe is to be fitted with a valve.

The coefficient found in Table 2 for the a.m. parameters is 1, therefore, the heating cable will be laid along the pipe. Next, ELEKTRA FreezeTec™ 12/15 heating cable 15 m long is selected from Table 1. The cable length exceeds that of pipe by 1 m. The additional length of 1 m is used for valve heating while the remaining length of cable is laid along the opposite side of pipe. The cable may also be wound with small pitch around the pipe so as to use the whole cable length.

### Example 2

- 12 m long 32 mm DN pipe (outer diameter of the pipe - 42 mm).
- 10 mm thick insulation;
- min. ambient temperature: -25°C;
- the pipe has no flanges, valves etc.

The value of coefficient (Table 2) for the a.m. parameters is 1.5. Therefore, the length of heating cable will be: 12 m x 1,5 = 18 m. ELEKTRA FreezeTec™ 12/21 heating cable 21 m long is selected. The cable should be helically wound around the pipe. The pitch [p] may be calculated using the following formula:

$$p = \frac{\pi((D+d)L_R)}{\sqrt{L_P^2 - L_R^2}}$$

- where: D - outer diameter of pipe  
d - dimension of heating cable  
L<sub>P</sub> - heating cable length  
L<sub>R</sub> - pipe length

In the a.m. example:

D - outer diameter of pipe is 4.2 cm

d - dimension of heating cable is 5 x 7 mm

$L_P$  - heating cable length is 2100 cm

$L_R$  - pipe length is 1200 cm

$$p = \frac{\pi((D+d)L_R)}{\sqrt{L_P^2 - L_R^2}} = \frac{\pi((4,2+0,7)1200)}{\sqrt{2100^2 - 1200^2}} = \frac{18840}{1723,30} = 10,7 \text{ [cm]}$$

Thus, the cable has to be wound around the pipe so that the distance between cable runs is about 11 cm.

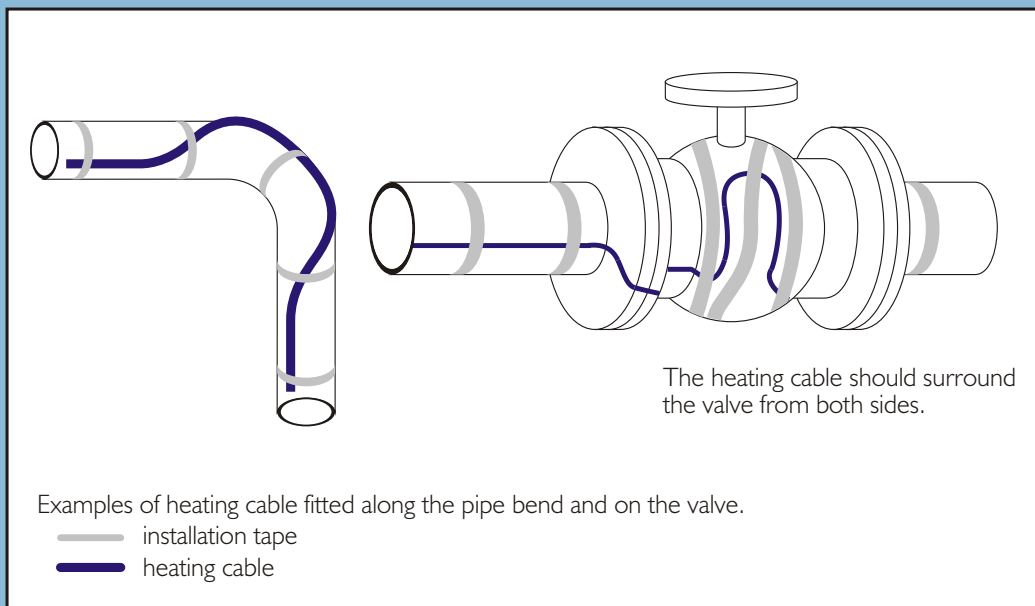

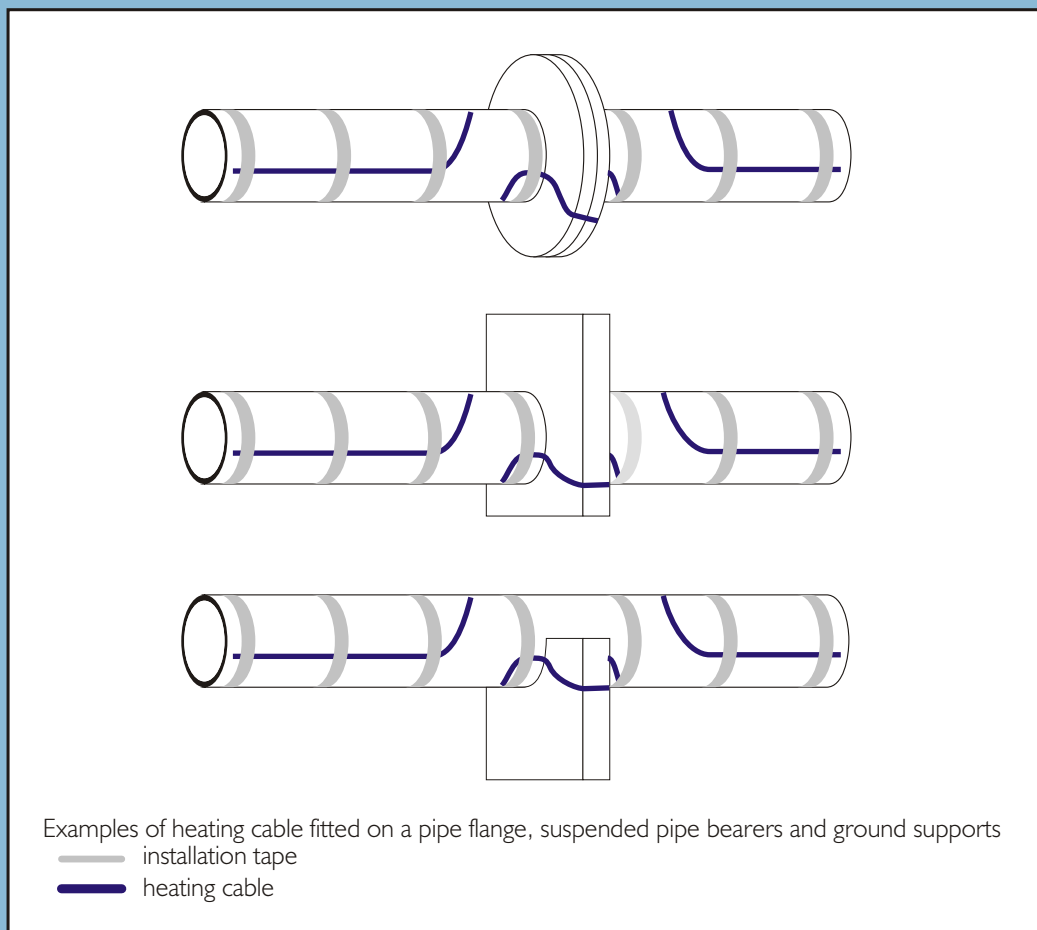

**NOTE:** Heating cables fitted on valves, flanges or supports cannot come into contact with each other. To prevent possible displacement, the cable should be fitted with extra tape lengths.

### STAGE 3

After the ELEKTRA FreezeTec™ cable is placed on the pipe, it must be fixed with self-adhesive aluminium tape along the whole cable length.

**NOTE:** If plastic pipes are to be heated, then the self-adhesive tape should be used under the cable. The use of aluminium adhesive tape ensures that the cable adheres to the pipes securely and accurate heat transmission is facilitated. The tape also prevents the cable from being pushed into the thermal insulation, which could cause possible overheating.

#### **STAGE 4**

The pipes and heating cables must be insulated. To enable correct operation of the system the insulation should be at least 10 mm thick though should not exceed a max. of 20 mm thickness. Thermal insulation should also be provided on the thermostat.



**ELEKTRA**<sup>®</sup>



SILVER ACE '93



BRONZE HELMET '97



SILVER HELMET '98



GOLD HELMET '97



GOLD MEDAL  
MTP Poznań '2001



ul. Marynarska 14  
02-674 Warszawa, Poland  
tel.: (+48 22) 843 32 82  
fax: (+48 22) 843 47 52  
e-mail: [office@elektra.pl](mailto:office@elektra.pl)  
[www.elektra-heating.com](http://www.elektra-heating.com)

**ELEKTRA (UK) LTD**

Elektrek House  
19 Manning Road  
Felixstowe  
Suffolk  
IP11 2AY

**Tel: 01394 270777 Fax: 01394 670189**

e-mail: [info@elektra-uk.com](mailto:info@elektra-uk.com) [www.elektra-uk.com](http://www.elektra-uk.com)