

ELEKTRA DM

Single-side powered heating cables

Power output of 10 W/m.



Characteristics and application

ELEKTRA DM heating cables are manufactured according to IEC800 standard. They consist of a thin heating cable (power output of 10 W/m) terminated with a cold tail cable.

ELEKTRA DM heating cables are designed for indoor floor heating systems. DM cables should be installed in the flexible tile adhesive layer or in the self-leveling mix, directly under the flooring.

T Technical parameters

- power output - 10W/m;
- power supply - 230 V 50/60 Hz;
- external cable diameter - 4.3 mm;
- type of cold tail cable - LiYCY 2x0.75mm², shielded;
- length of cold tail cable - 2.5 m;
- protection type - cable shielded on the entire length. The cable should be connected via a residual current device, which constitutes an effective protection against electric shock.

Table 1.

TYPE	LENGTH	POWER
-	m	W
DM10/90	9	90
DM10/130	13	130
DM10/150	15	150
DM10/220	22	220
DM10/280	28	280
DM10/320	32	320
DM10/400	40	400
DM10/450	45	450
DM10/550	55	550
DM10/690	69	690
DM10/780	78	780
DM10/980	98	980
DM10/1100	110	1100

ATTENTION: Values shown in the table may vary by up to 5%.

S Selection

Choice of the heating cable depends on the type of room and type of heating system.

Table 2.

HEATING SYSTEM TYPE	TYPE OF ROOM	
	BATHROOMS	OTHER ROOMS
	HEATING UNIT POWER	HEATING UNIT POWER
	W/m ²	W/m ²
PRIMARY HEATING ¹⁾	80 to 120	70 to 90
AUXILIARY HEATING ²⁾ (WARM FLOOR EFFECT)	80 to 120	80 to 120

¹⁾ Selection of power for the room = unit heating power x total room area

²⁾ Selection of power for the room = unit heating power x actual area of the floor to be heated

E Examples

Example 1

- Total bathroom area - 8 m²;
 - Type of heating - primary (Figure 1);
 - Heating unit power - 120 W/m²;
 - Calculated heating power for the total bathroom:
 $8 \text{ m}^2 \times 120 \text{ W/m}^2 = 960 \text{ W}$;
 - Select appropriate cable from Table I, DM10/980;
 - Power of the selected cable - 980 W;
 - Length of the set - 98 m;
 - Unfurnished area of bathroom floor - 5.5 m².
- Calculated distance between cables is:
 $5.5 \text{ m}^2 : 98 \text{ m} = 0.56 \text{ m} = 5.6 \text{ cm}$

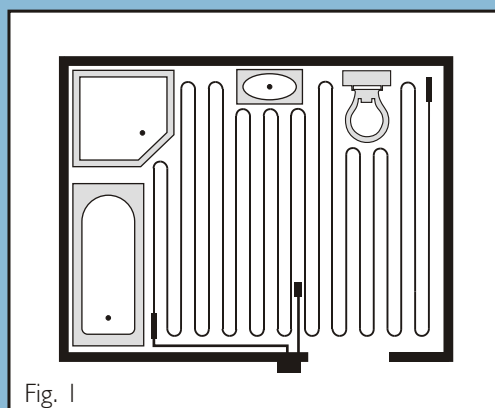

Fig. 1

Example 2

- Total bathroom area - 8 m²;
 - Type of heating - auxiliary (warm floor effect) (Figure 2);
 - Heating unit power - 90 W/m²;
 - Unfurnished area of bathroom floor - 5.5 m²;
 - Heating power $5.5 \text{ m}^2 \times 90 \text{ W/m}^2 = 495 \text{ W}$;
 - Select appropriate cable from Table I, DM10/550;
 - Power of the selected cable - 550 W;
 - Length of the set - 55 m.
- Calculated distance between cables is:
 $5.5 \text{ m}^2 : 55 \text{ m} = 0.10 \text{ m} = 10 \text{ cm}$

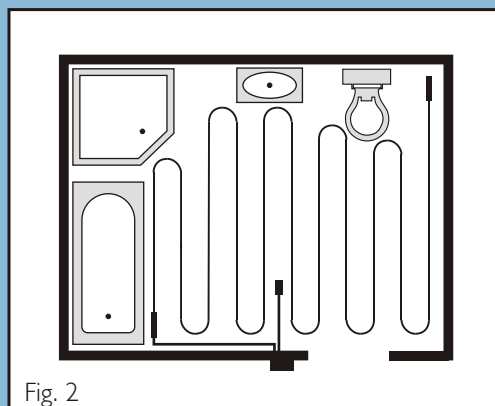

Fig. 2

NOTE: For any type of heating system the distance between installed ELEKTRA DM heating cables must not be less than 5 cm. When calculating the distances between heating cables only the floor surface "unfurnished" with fixed elements, such as furniture without legs, bathtub, toilet, etc., and storage places located directly on the floor, must be taken into consideration.

Installation conditions

ELEKTRA DM heating cables must be installed according to the following instructions:

- Installation, connection to the power supply and necessary tests must be performed by a qualified electrician;
- Heating cables must not be installed in places where fixed furniture is planned (e.g. bathtubs, lockers without legs, etc.);
- Heating cables should not cross expansion joints in the floor;
- Where finished flooring is tiles, flexible adhesive and grout must be used, in order to prevent the cracking of the flooring.

T Temperature control

Temperature controller is a necessary element of a floor heating system. It assures the correct operation of heating elements. Selecting the correct temperature controller guarantees optimum heating results according to user's expectations.

There are two primary types of controllers:

- with floor sensor;
- with air sensor and limitation floor sensor (this type of controller measures the air temperature and at the same time the floor sensor protects the heating cables and floor against overheating).

Controllers with floor sensors only are used for maintaining required floor temperature. They are usually used when the ELEKTRA DM heating system is only supplementary to the existing (basic) heating system, in order to obtain the warm floor effect, or to provide additional heating for selected areas.

Controllers with air sensor and limitation floor sensor are used when the user wants to obtain optimum air temperature in a given room, this is the case when the ELEKTRA DM heating cables are used as the primary heat source in the room.

Table 3 Example temperature controllers

CONTROLLER NAME	CONTROLLER TYPE
ELEKTRA ELR-10 ELEKTRA Microline OTN/OTDC	Equipped with floor sensor or air sensor with limitation floor sensor
ELEKTRA Microline OCC2/OCD2	Programmable with floor sensor or air sensor with limitation floor sensor
ELEKTRA DIGI2p	Programmable with floor sensor

Installation

NOTE: ELEKTRA DM heating cables are designed for installing directly in the flexible tile adhesive or in the self-leveling compound. Prior to installing the cables, a groove must be made in the flooring to accommodate a protective tube in which the temperature sensor will be installed. The protective tube with the temperature sensor inside must be installed in such a way that it will be located at equal distance between the cables.

STAGES OF THE WORKS

STAGE I.

Power supply installation and fitting the temperature controller (Fig. 4).

- 1) Select the place for the temperature controller, according to esthetical and practical sense - usually next to the light switches.

NOTE: Controllers for bathrooms or other high-humidity areas must always be installed outside such room (in order to protect it against humidity), a controller with floor sensor must be used in such cases. Controllers with air sensor and limitation sensor must be installed at the height of ~ 1.4 m from the floor, in a place not exposed to draughts and direct sunlight.

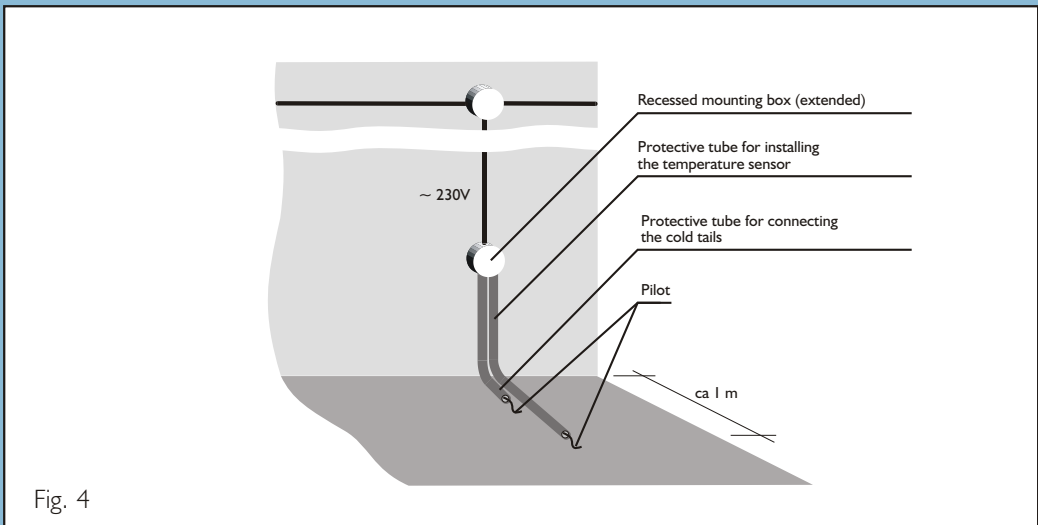

- 2) Install a single gang back box for the temperature controller.
- 3) Install a 230V 50/60Hz three-wire power supply cable to the back box.
- 4) Connect two protecting conduits (tubes) with draw wires to the box; after laying the heating cables the pipes will be used to install:
 - a) floor temperature sensor cables;
 - b) cold tail cable of the ELEKTRA DM heating cable.

NOTE: The protective conduits (tubes) at the angle of the wall and the floor must not bend at right angles, the curved shape as shown on Figure 6 must be maintained; the draw wires, will facilitate the installation of the floor sensor cable and the ELEKTRA DM cold tail cable into the temperature controller back box.

STAGE 2.

Laying the cables.

1. The insulation and wire resistance measurements of each ELEKTRA DM heating cable must be performed prior to installation. The insulation resistance measured at 1000V must not be less than 10MW.
2. The surface on which the ELEKTRA DM cables will be placed must be thoroughly cleaned, leveled and primed. Only a surface prepared this way will make it possible to install the cables by fixing them with hot adhesive as shown on Figure 5.

ELEKTRA DM heating cables must be placed at correct distances from each other; as specified in the Note on page 5.

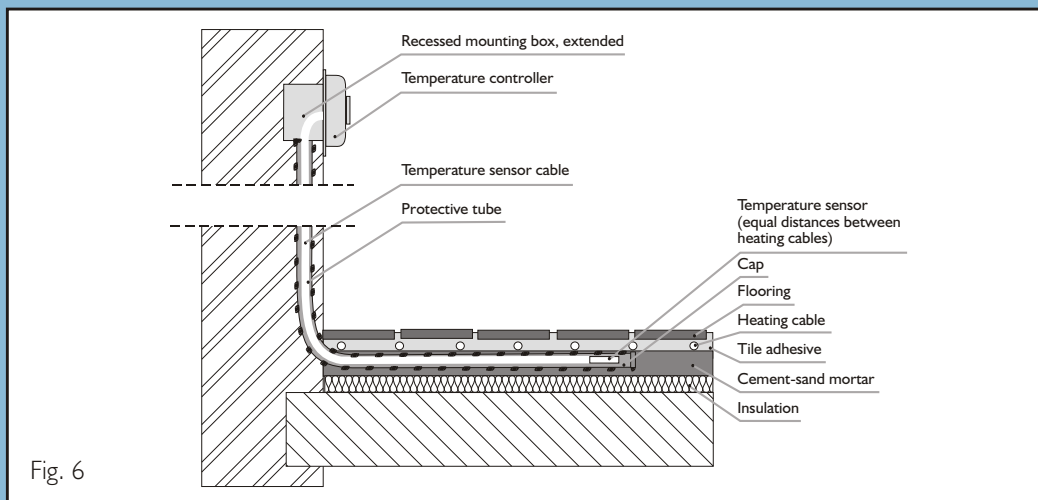

Fig. 5

ELEKTRA DM heating cables can also be installed by fixing them to a fine metal wire mesh or using special ELEKTRA TME installation tape. This installation method requires increased amount of adhesive or self-leveling mix, thus increasing the flooring thickness.

The cables must not move during the installation works. So it is essential that the cables are fixed to the floor or the mesh.

The connection sleeve - the point of connection of the heating and cold tail cable must always be embedded in the adhesive or self-leveling compound.



STAGE 3.

Connecting the cables to the temperature controller.

After the ELEKTRA DM heating cables and temperature sensor cable are installed they must be connected to appropriate terminals of the controller, according to the instructions given in the manual of the controller.

NOTE: The protective wire of the ELEKTRA DM heating cable is made in the form of a copper shield. Prior to connecting it to the 230 V power supply's earth wire (green-yellow) the shield must be gently twisted into a uniform wire. This must then be sleeved using green-yellow insulation sleeve or green-yellow insulation tape.

STAGE 4.

Electrical measurements of installed heating cables must be performed before and after covering them with adhesive or self-leveling compound.

The following measurements must be performed:

- wire resistance;
- insulation resistance.

The insulation resistance of any ELEKTRA DM heating set measured, using a device with rated voltage of 1000V must not be less than 10MW.

P Protection against electric shock

Absolute safety of ELEKTRA DM heating set is assured by a copper shield covering the entire length of the heating cable and the cold tail cable. The shield must be connected to a protective cable (PE) as shown on Figure 7. A $D \leq 30$ mA residual current device protecting against electric shock must be installed in heating installations. This residual current device can be a common device for multiple circuits. When ELEKTRA DM heating cables are installed in rooms, where there is no residual current device such a device must be installed for the heating cables.

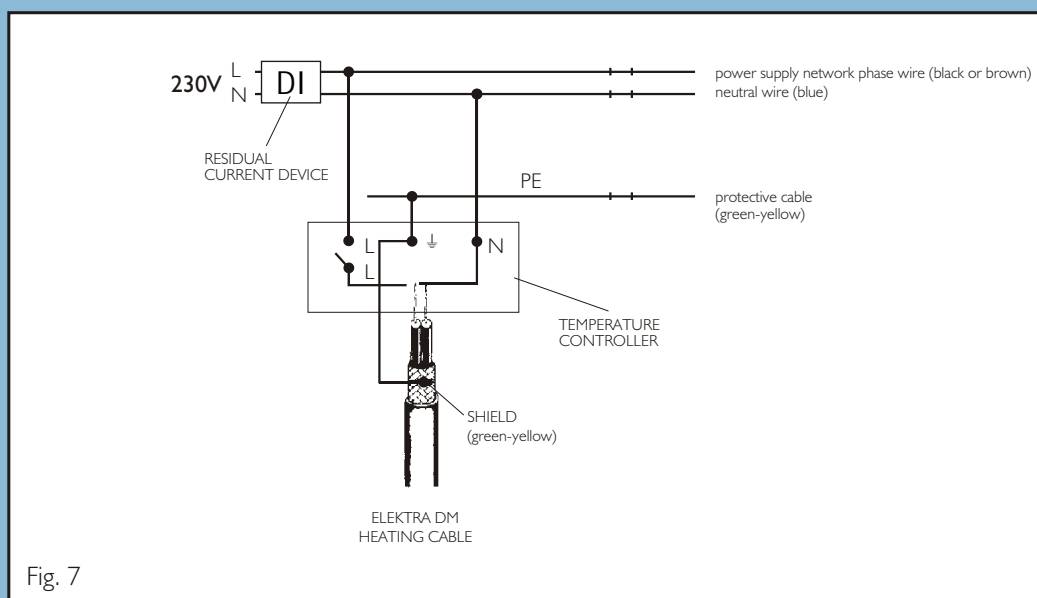

Fig. 7



Operating the heating system is simple, just set the desired temperature on the temperature controller. The user must bear in mind that the entire floor, or a part of it, is a heater, and because of this the user should not make such changes to the room or room furnishing, which could obstruct the heat emitting from the floor. No large-area objects should be put on the floor, such as mattresses, or furniture without legs that contacts the floor with its entire area. Holes can be drilled in the floor only after checking where the heating cables are located (based on the as-installed documentation or heating cable route located with an appropriate device).



ELEKTRA[®]



SILVER ACE '93



BRONZE HELMET '97



SILVER HELMET '98



GOLD HELMET '97



GOLD MEDAL
MTP Poznan '2001



ul. Marynarska 14
02-674 Warszawa, Poland
tel.: (+48 22) 843 32 82
fax: (+48 22) 843 47 52
e-mail: office@elektra.pl
www.elektra-heating.com

ELEKTRA (UK) LTD

Elektrek House
19 Manning Road
Felixstowe
Suffolk
IP11 2AY

Tel: 01394 270777 Fax: 01394 670189

e-mail: info@elektra-uk.com www.elektra-uk.com